

5min

1

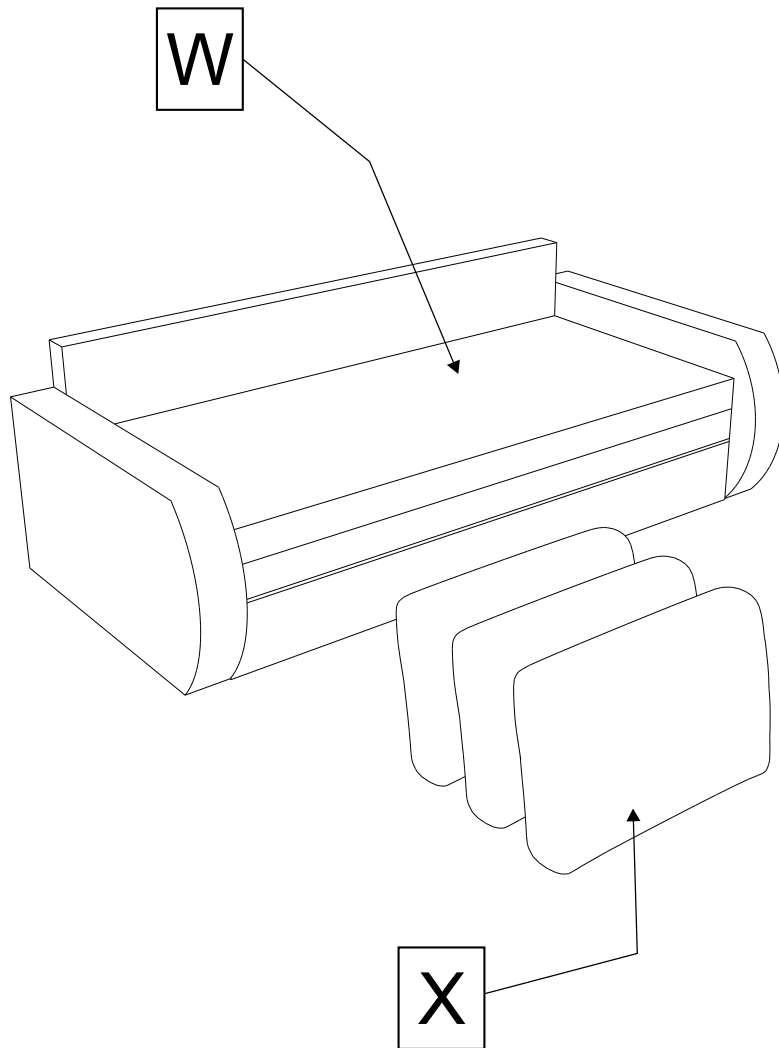

W	1x
X	3x



1

